

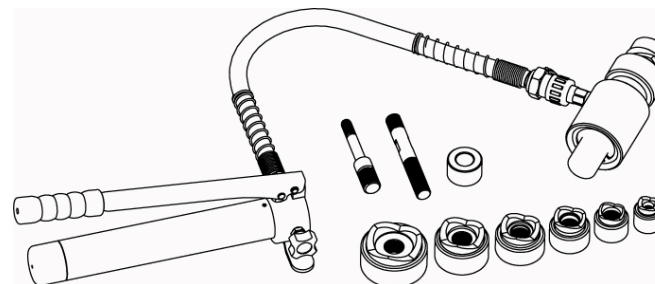

eclipseSM

Instruction Manual

Hydraulic Punch Driver 902-545



Due to continuing improvements, actual product may differ slightly from the product described herein.



Read this material before using this product.

Failure to do so can result in serious injury.

SAVE THIS MANUAL

SAVE THIS MANUAL

Keep this manual for the safety warnings and precautions, assembly, operating, inspection, maintenance and cleaning procedures. Write the month and year of purchase. Keep this manual and the receipt in a safe and dry place for future reference.

IMPORTANT SAFETY INFORMATION

In this manual, on the labeling, and all other information provided with this product:



This is the safety alert symbol. It is used to alert you to potential personal injury hazards. Obey all safety messages that follow this symbol to avoid possible injury or death.

▲ DANGER

DANGER indicates a hazardous situation which, if not avoided, will result in death or serious injury.

▲ WARNING

WARNING indicates a hazardous situation which, if not avoided, could result in death or serious injury.

▲ CAUTION

CAUTION, used with the safety alert symbol, indicates a hazardous situation which, if not avoided, could result in minor or moderate injury.

LIMITED 1 YEAR WARRANTY

We make every effort to assure that its products meet high quality and durability standards, and warrants to the original purchaser that this product is free from defects in materials and workmanship for the period of one year from the date of purchase (90 days if used as rental equipment). This warranty does not apply to damage due directly or indirectly, to misuse, abuse, negligence or accidents, repairs or alterations outside our facilities, normal wear and tear, or to lack of maintenance. We shall in no event be liable for death, injuries to persons or property, or for incidental, contingent, special or consequential damages arising from the use of our product. Some states do not allow the exclusion or limitation of incidental or consequential damages, so the above limitation of exclusion may not apply to you. **THIS WARRANTY IS EXPRESSLY IN LIEU OF ALL OTHER WARRANTIES, EXPRESS OR IMPLIED, INCLUDING THE WARRANTIES OF MERCHANTABILITY AND FITNESS.**

To take advantage of this warranty, the product or part must be returned to us with transportation charges prepaid. Proof of purchase date and an explanation of the complaint must accompany the merchandise. If our inspection verifies the defect, we will either repair or replace the product at our election or we may elect to refund the purchase price if we cannot readily and quickly provide you with a replacement. We will return repaired products at our expense, but if we determine there is no defect, or that the defect resulted from causes not within the scope of our warranty, then you must bear the cost of returning the product.

The warranty gives you specific legal rights and you may also have other rights which vary from place to place.

2. **After using**, clean external surfaces of the tool with a clean, moist rag and rub rust preventing oil on the metal surfaces of the tool and the dies to avoid rust. Store the tool in the dry environment.
3. Service to the tool should only be done by a qualified Service Technician.
4. After a long time using, the sealing kits will be damaged, if there is leakage please contact with the manufacturer and/or the distributor to change the sealing kits.

▲CAUTION

Please wear rubber gloves to avoid skin touching the oil directly, if touched, please wash the skin by soap water immediately. In order to protect the environment please drain the waste oil to the treatment center where was approved by government.

TROUBLESHOOTING

FAULT	ANALYSIS	SOLUTION
A. No pressure or the pressure is not enough during operation	1. The pump lacks oil 2. There is dust in oil 3. Inner leakage	1. Fill the oil 2. Change the oil 3. Contact manufacturer or distributor
B. Oil leakage on the head or on the ram	1. Sealing kit broken	1. Contact manufacturer or distributor and replace it by trained person

PLEASE READ THE FOLLOWING CAREFULLY

THE MANUFACTURER AND/OR DISTRIBUTOR HAS PROVIDED THE PARTS LIST AND ASSEMBLY DIAGRAM IN THIS MANUAL AS A REFERENCE TOOL ONLY. NEITHER THE MANUFACTURER NOR DISTRIBUTOR MAKES ANY REPRESENTATION OR WARRANTY OF ANY KIND TO THE BUYER THAT HE OR SHE IS QUALIFIED TO MAKE ANY REPAIRS TO THE PRODUCT, OR THAT HE OR SHE IS QUALIFIED TO REPLACE ANY PARTS OF THE PRODUCT. IN FACT, THE MANUFACTURER AND/OR DISTRIBUTOR EXPRESSLY STATES THAT ALL REPAIRS AND PARTS REPLACEMENTS SHOULD BE UNDERTAKEN BY CERTIFIED AND LICENSED TECHNICIANS, AND NOT BY THE BUYER. THE BUYER ASSUMES ALL RISK AND LIABILITY ARISING OUT OF HIS OR HER REPAIRS TO THE ORIGINAL PRODUCT OR REPLACEMENT PARTS THERETO, OR ARISING OUT OF HIS OR HER INSTALLATION OF REPLACEMENT PARTS THERETO.

GENERAL SAFETY RULE

TO WORK IN SAFE CONDITIONS WITH THIS TOOLING, IT IS IMPERATIVE TO READ CAREFULLY THE DIRECTIONS FOR USE AND TO FOLLOW THE INSTRUCTIONS IT CONTAINS. IF YOU DO NOT RESPECT THE INFORMATION WRITTEN IN THAT INSTRUCTION MANUAL THE WARRANTY WILL BE CANCELLED.

1. Work area safety

- a. Keep work area clean and well-lit. Cluttered or dark areas invite accidents.
- b. Keep children and bystander away while operating the hydraulic punch driver. Distractions cause you losing control.
- c. Please do not use or store this tool under high temperature, or one surrounding filling with corrosive fluid. Pay attention to the sealing kits becoming aging.

2. Personal safety

- a. Stay alert, watch what you are doing and use common sense when operating the tool. Do not use the tool while you are tired or still under the influence of drugs, alcohol or medication. A moment of inattention may result in series personal injury.
- b. Use safety equipment. Always use safety equipment such as eye protector, safety cap, etc to reduce the risk of personal injury.
- c. Please use the tool properly, the tool with correct power will do the job better and safer at the rate for which it was designed.
- d. Do not put your fingers in the head of the hydraulic punching tool during operating. Your fingers could be pinched very severely.

3. Service

Have your Hydraulic Punch Driver serviced by a qualified service technician using only identical replacement parts. This will ensure that the safety of the Hydraulic Punch Driver Kit is maintained.

SPECIFIC SAFETY RULES

1. Maintain labels and nameplates on the tool which carry important safety information. If unreadable or missing, contact with the agent to replace.
2. This product is not a toy, keep it out of reach of children.
3. Do not slide your fingers in the punch dies profile.
4. Do not use the tool without punch die.
5. Release the hydraulic pressure before disconnecting the hoses or couplers, and Before servicing the pump or accessory
6. Hand –tighten all couplers completely before operating the pump.
7. Do not use hands to check for leakage.
8. Do not hold hose or coupler while the hydraulic system is pressurized.
9. Do not use this tool near, live circuits.
10. The warnings, precautions, and instructions discussed in this instruction manual cannot cover all possible conditions and situations that may occur. It must be understood by the operator that common sense and caution are factors which cannot be built into this product, but must be supplied by the operator.



SAVE THESE INSTRUCTIONS

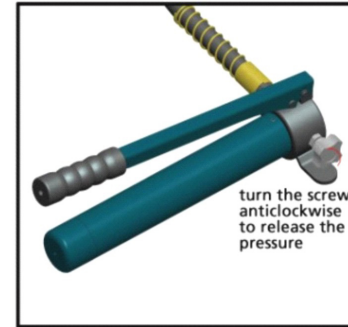

7.

Standard punch & die size: Ø ½, ¾, 1, 1-1/4, 1-1/2, 2, 2-1/2 inch



The size is marked on the surface of the punch die.

MAINTENANCE AND SERVICING

⚠WARNING

Damaged equipment may cause serious personal injury. Do not use damaged equipment. If abnormal noise or vibration occurs, have the problem corrected before further using.

1. **Before each use**, inspect the general condition of the tool. Check for loose screws, misalignment or binding of moving parts, cracked or broken parts, or any other condition that may affect its safe operation.

6. Turn the screw counter-clockwise to release the pressure at the pump.

⚠WARNING

Do not allow anyone to stand in front of the punch or behind the hydraulic ram. Ignore this warning can result in injury or damage.

Please refer the illustration below

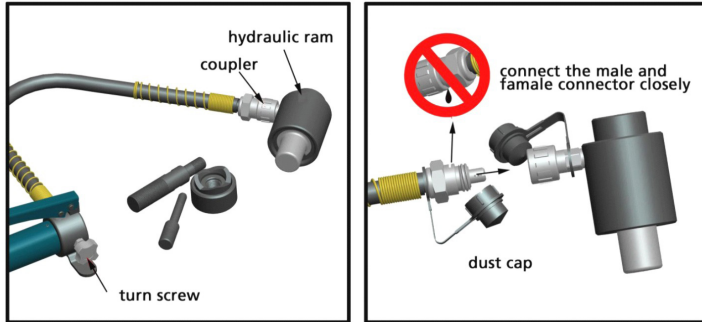

1.

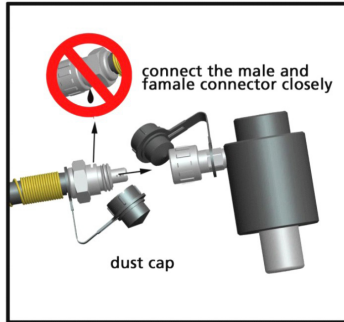

2.

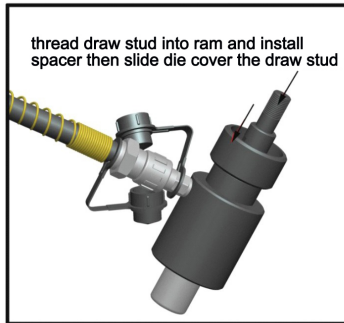

3.

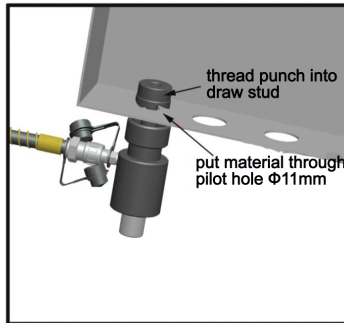

4.

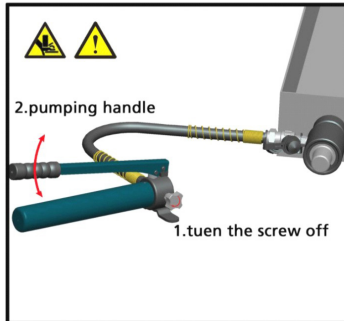

5.

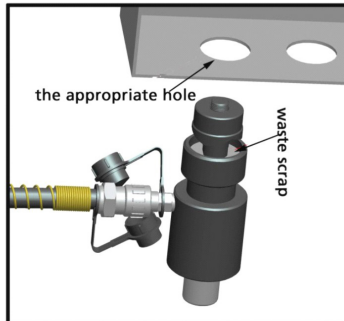

6.

UNDERSTAND YOUR TOOL

902-545 is a tool for punching mild metal plate. It carries many advantages of good design, easy operation, high pressure, high efficiency etc. It is the perfect tool to be used in electrical and construction sites.

1. Specification

Item	902-545			
Punching range:	\varnothing 1/2" – 4" below .14 inch mild steel plate Comes with slug breaking round punches 1/2" to 2-1/2" Conduit (capable up to 4" with 902-546 punch set sold separately).			
Punching force:	15 Ton			
Stroke:	1 inch			
Weight: Approx.	15.6 lbs			
Weight of box:	5.5 lbs			
Oil capacity:	5.6 oz			
Oil:	15# hydraulic oil			
Package:	Steel case			
Ambient temperature:	-20°C -40°C			

Accessories:

ITEM NO				
Round Knockout Punches Type C	1/2, 3/4, 1, 1-1/4, 1-1/2, 2, 2-1/2 inch conduit			
Draw Stud	7/16"-3/4": 1 pc 3/4"-3/4": 1pc			
Spacer	1 pc			

OPERATING INSTRUCTIONS.

2. Description of the components.

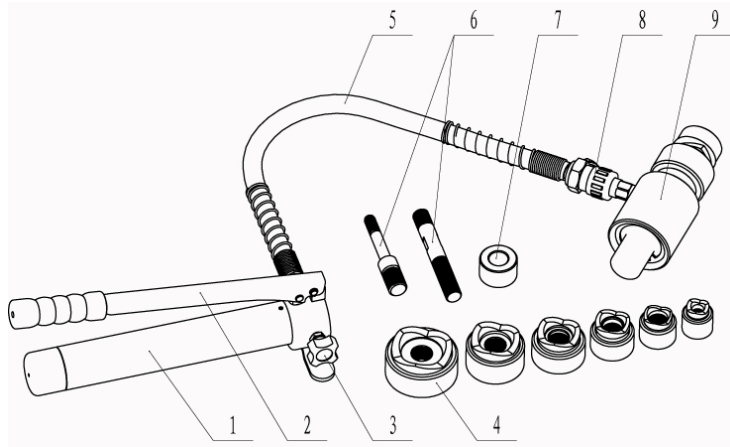

Code	Name	Function
1	Pump	For storing the oil
2	Active handle	For operating
3	Turn screw	For releasing pressure and retracting piston
4	Punch die	For punching the hole
5	Oil hose	Carrying the oil
6	Draw stud	Connects with the punch die for punching
7	Spacer	To protect the punching head
8	Coupler	Connector
9	Ram	Fix the draw stud, output power

Read the entire SAFETY INFORMATION section at the beginning of this manual including all text under subheadings therein before using this product.

Use this tool for the manufacturer's intended purpose only. Use other than that which is described in this manual can result injury or property damage.

1. Select the appropriate punch, die and draw stud for appropriate size hole.

⚠WARNING

Do not exceed the rated capacity of this tool; otherwise it will cause a component failure, which could throw broken parts with great force. Failure to observe this warning can result injury or death.

2. Drill a pilot hole by electric drill on the metal sheet, then use a drill bit that is slightly larger than the draw stud, drill a hole.
3. Thread the draw stud completely into the ram..
4. Slide the spacer onto the draw stud to protect the cylinder, and the die after, then let the metal sheet go through the draw stud by the hole. Lastly thread the punch facing the steel plate. Make sure the spacer, punch, die and material are as tight as possible by hand.

⚠DANGER

An improper setup could cause the components to be damaged.

5. Pump the pump handle until completely punched.

⚠CAUTION

Do not operate the pump after ram motion stops. Continuing to operate the pump lever after the ram stops will damage the ram. If the ram stops before the hole is complete, stop pumping, check that the setup is correct and that you have not exceeded the tool's capacity. See the setup instruction.. if necessary, disassemble the setup and add or remove the spacer.

⚠CAUTION

Make sure the punching cycle is completed during the operation to avoid the scrap remaining the down punch.

